

ROLLER SHUTTER MODULE WITH POSITIONING (ROL01PSA) (Stand-Alone)

"



ROL01PSA, Roller shutter module

1. Product description

Module for DIN rail installation, suitable for switching and positioning one roller shutter. This module is part of the Qbus Stand-Alone range and can work on its own, so WITHOUT a Qbus Controller, or it can also be connected to a Qbus controller and then be part of a full Qbus home automation system.

The roller shutter module has one Up and one Down input and can thus control one roller shutter. The ROL01PSA is also equipped with a normally closed input for connecting a weather station so that shutters can be closed or opened automatically in case of strong winds. The protective input is supplied standard with a bridge. The module can also be used to position blinds. Like any stand-alone module, the ROL01PSA has an All On/All Off input. Two feedback outputs can be used to connect feedback LEDs (UP/DOWN).

The roller shutter motor that is connected to the ROL01PSA must be a 230V AC motor, with a minimum load of 40VA and a maximum load of 500VA. The roller shutter motor must also have limit switch contacts; this is important for the calibration of the shutters. The ROL01PSA does not allow Up and Down contacts to be controlled simultaneously. The electronics is provided with an automatic current detection so that the current level can be adjusted automatically during the calibration.

Blinds can be positioned manually between 0% and 100% in 10 steps.

An internal calibration mechanism will calibrate the shutter each time that it is fully raised or lowered (each time a limit switch contact is activated). This ensures that the required roller shutter position also remains accurate after a period of time.

Caution: in the first software version of the module, the calibration can only be carried out by means of a controller. This controller can be removed after the configuration in order to put the module in stand-alone mode.

Each module has a unique serial number (6 digits). The module can be programmed using the Qbus software based on this serial number.

Limit switch contacts must first be manually adjusted prior to connecting to the module. Qbus is not responsible for any damage caused by poor adjustment of the roller shutter motor.

The module has two status LEDs on the front.

Reset functionality is provided by using the push-buttons on the module. Go in the menu and press the relevant channel for five seconds to reset. This returns all parameters to their default values.

The ROL01PSA is by default set in shutter mode (not in blind mode). The mode can be changed by using the push-buttons on the module.

Operating in shutter mode:

- A short pulse makes sure that the module goes to 0% or 100%.
- A second short pulse stops the motor.
- A long pulse (more than 300ms) ensures that the motor moves in the selected direction up to when the button is released.

Thermal cut-out protection feature:

- This option ensures that the roller shutter can only be fully open or fully closed, so that the temperature of the glass is kept constant everywhere and glass breakage is avoided.

Operating in blind mode:

- A short pulse allows the motor to tilt the blinds one step. To go from the horizontal to the vertical position, ten steps are provided as standard (five in each direction). The number of steps can be set in the System Manager.
- A pulse of about one second makes sure that the module goes to 0% or 100%. A short pulse in one of the two directions stops the motor.
- A long pulse (more than 1s) ensures that the motor moves in the selected direction up to when the button is released.

If the module is restarted after a power interruption, the outputs will again be in their last position.

A two-pole automatic fuse with a maximum of 16A must be connected to the power supply module.

ROLLER SHUTTER MODULE WITH POSITIONING (ROL01PSA) (Stand-Alone)

2. Safety rules

Read the entire manual before installing the module and activating the system.



CAUTION

- The module must be installed, started and maintained by a qualified electrician in accordance with the applicable national legal regulations.
- This module is only suitable for DIN-rail installation EN50022. The module must be installed in a fireproof, closed distribution cabinet with ventilation grilles.
- The power must be switched off before working on the ROL01PSA.
- The module may not be opened. The warranty will expire once the module is opened!
- Preventive maintenance of the module is not required.

3. Installation and wiring

The ROL01PSA can be used in different ways. The following properties remain the same for each cabling method:

INSTALLATION:

Click the module on a DIN rail DIN EN50022.

INPUTS:

Remove approximately 7 mm of insulation from the cable and place the cable in terminals 1-A. Both fixed and flexible wire between 0.5 to 1.5 mm² can be used. Push down on the terminal with a screwdriver when inserting a flexible wire.

Inputs 1 and 2 operate the UP/DOWN function of the module. Input A is by default set as a mood input. By holding the push-button linked to the input for 0.7 seconds, the roller shutter will close (0%). If you hold this push-button longer than 3 seconds, the roller shutter will open (100%).

The wires can be pulled out of the terminals by using a screwdriver to push at the top of the terminals.

LED OUTPUTS:

An external 24V power supply can be connected to the ROL01PSA to provide LED feedback for 2 push-buttons using the LED outputs.

LOAD:

Connect the loads as shown in the figure on the next page. The cross-section of the conductor: at least 1.5 mm². Both fixed and flexible wire may be used for the conductor.

Remove approximately 7 mm of insulation from the conductor and screw it into the UP – DN connectors.

POWER SUPPLY:

A two-pole automatic fuse with a maximum of 16A must be connected to the 230Vac power supply module.

Cross-section of the conductor: minimum of 1.5 mm².

Remove approximately 7 mm of insulation from the conductor and screw it into connector LN.

ATTENTION:

DISRUPT THE POWER SUPPLY TO THE MODULE BEFORE CARRYING OUT WORK TO THE MODULE.

LED INDICATION ON THE MODULE:

Green: power supply (230V AC present or present in the BUS).

Red: flashes 3 times during start-up and afterwards during programming.

Orange: UP/DN active. Blinks if not calibrated and during calibration.

MANUAL OPERATION:

Used to operate the shutter/blind directly from the module. Each function can be operated via the button under the corresponding output.

MENU SETTINGS:

Always take the following steps to change this configuration:

1. Ensure that all outputs are OFF (= all orange LEDs are off).
2. Hold buttons 1 and 2 simultaneously for five seconds.
3. The red STATUS LED on the module will flash rapidly for 5 seconds and then slower.
4. Once the STATUS LED has started to flash slowly, release one of the buttons and hold the other button for 2 more seconds. The red STATUS LED will now continue to flash for 10 seconds: the module is in configuration mode.
5. Now press the number of times corresponding to the selection in the table below.

Mode	Choice
ROL + position (shutter mode)	1
ROL + position + blinds (blind mode)	2
ROL + glass protection (UP/DOWN mode)	3

ROLLER SHUTTER MODULE WITH POSITIONING (ROL01PSA) (Stand-Alone)

WIRING METHOD

Stand-Alone with LED feedback

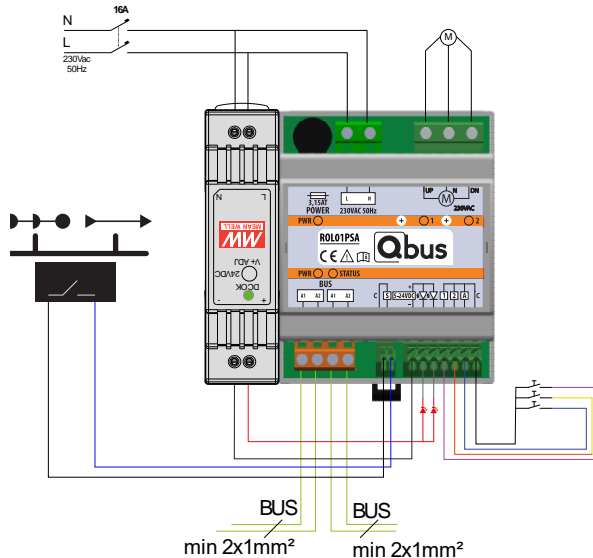

The mood inputs of several ROL01PSA modules can be interconnected.

4. Technical data

GENERAL SPECIFICATIONS:

- Power supply: 230V AC +/-10%, 50Hz - maximum protection 16A/2P
- Surge voltage: tested at 3 kV AC
- Typical consumption: 9 VA maximum – all relay outputs on.
- Ambient temperature:
 - Operating temperature: 10°C to 50°C
 - Storage temp. range: -10°C to 60°C
- Maximum humidity: 93%, no condensation
- Bus load: 8mA at nominal voltage 13.8V.
- Maximum installation height: 2,000 metres.

OUTPUTS:

- UP – DN: 230V AC output
- Maximum current: +/-2A (500VA)
- Contact resistance: 100mΩ
- Set/Reset time: 15ms max. / 5ms max.
- Life cycle: 20 million operations
- Minimum load: 40VA at 230V AC
- Maximum load: 500VA at 230V AC

PHYSICAL SPECIFICATIONS

- Housing: Plastic, self-extinguishing in accordance with UL94-V0
- Protection grade: IP20, EN60529
- Installation: rapid installation on DIN RAIL, width 4 modules
- Dimensions (HxWxL): 62 mm x 71 mm x 90.5 mm
- Weight: approximately 0.328 kg

ELECTRICAL SECURITY:

- Bus: 13.8V DC low voltage.

- In accordance with EN50491-5-1, EN50491-5-2, EN60529
- Surge voltage: module is tested and approved at 3kV AC. (50 Hz, 1 min)
- Non-toxic, in accordance with WEEE/RoHS

CE

- In accordance with EMC and low voltage regulations. Emissions and Immunity EN50491-5-1 and EN50491-5-2. Low voltage in accordance with EN60950-1

5. Dimension diagram

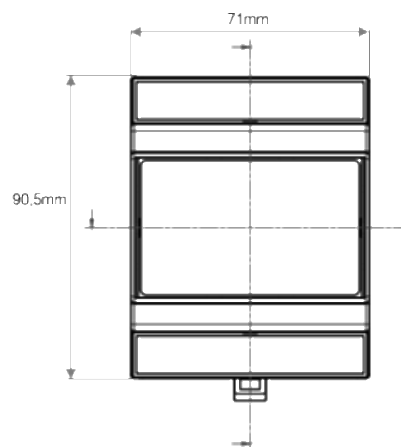

View from above

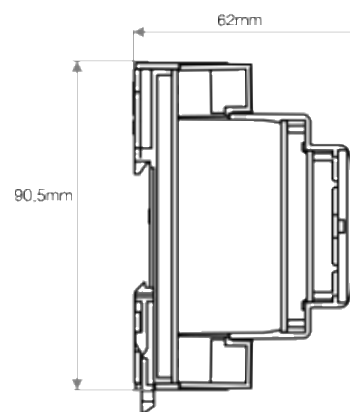

Side view

6. Guarantee provisions

Standard guarantee period: 4 years from date of delivery. Any faulty modules should be sent postage-free with a description of the defect to our customer service:

QBUS N.V.
Joseph Cardijnstraat 19
9420 Erpe-Mere
Belgium

T +32 53 60 72 10
F +32 53 60 72 19
Email: support@qbus.be

ROLLER SHUTTER MODULE WITH POSITIONING (ROL01PSA) (Stand-Alone)
